

CHAMPA

MENU

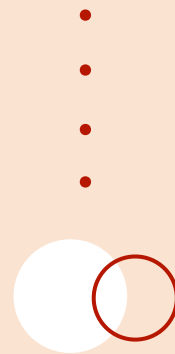
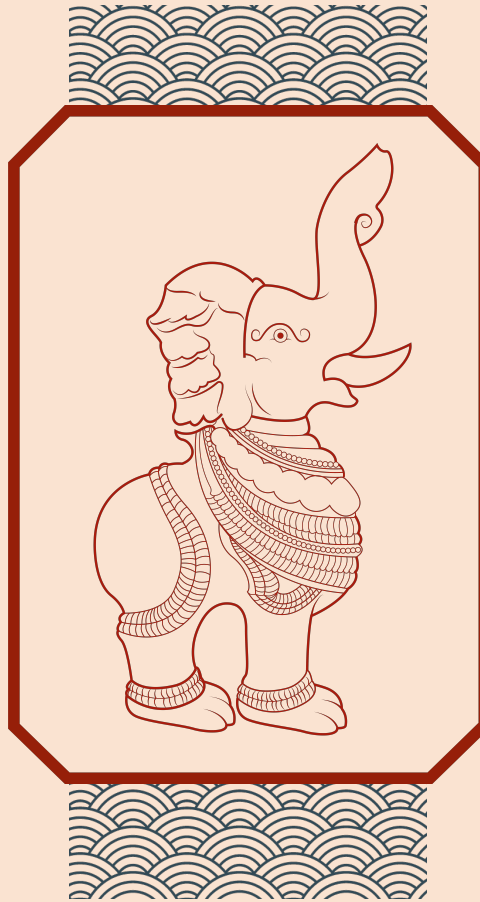

V O R S P E I S E

SUP CHAY	SAUER SCHARFE SUPPE VEGETARISCH Gemüse Pilze Kokosmilch Thai-Basilikum	6
MANGO SALAT	MANGOSALAT Gurke Karotte Chinakohl Kräuter Erdnüsse Fischsauce	6
FRIED CHICKEN	FRIED CHICKEN KARAAGE 6 STK Ingwer Sojasoße Spicy Mayo	6
CHICKEN GYOZA	CHICKEN GYOZA 3 STK Hühnchen Kohl Knoblauch Zwiebeln Frühlingszwiebeln-Dip Dumpling Sauce -optional- vegetarisch mit Gemüsefüllung	6
SPICY TUNA	SPICY TUNA TATAR Limette Daikon-Rettich rote Bete Sesam Frühlingslauch	12

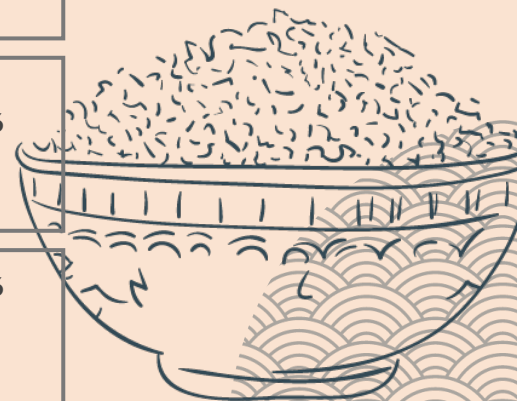

SUSHI

VEGAN

VEGAN SUSHI MENÜ

17

6 Maki Gurke
8 Inside Out Crispy Spargel & Paprika, Avocado
8 Inside Out Avocado, Gurke, Kürbis, Sesam

MIXED

MIXED SUSHI MENÜ

22

6 Maki Mango
8 Inside Out Shrimp Avocado
8 Inside Out Lachs, Gurke, Rucola, Frischkäse, Sesam

INSIDE OUT

INSIDE OUT SUSHI MENÜ

26

1 Nigiri Lachs
8 Inside Out Shrimp, Avocado
8 Inside Out Tuna, Chili, Gurke, Schnittlauch
8 Inside Out Lachs, Gurke, Rucola, Frischkäse, Sesam

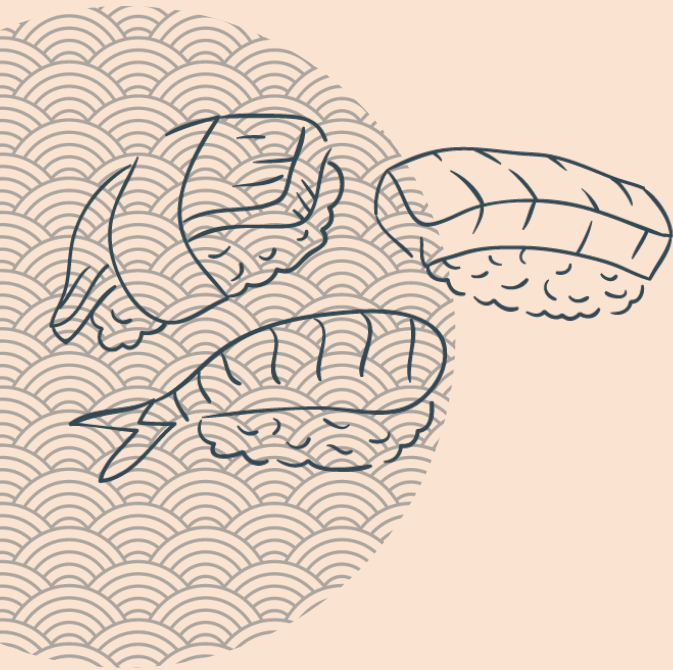
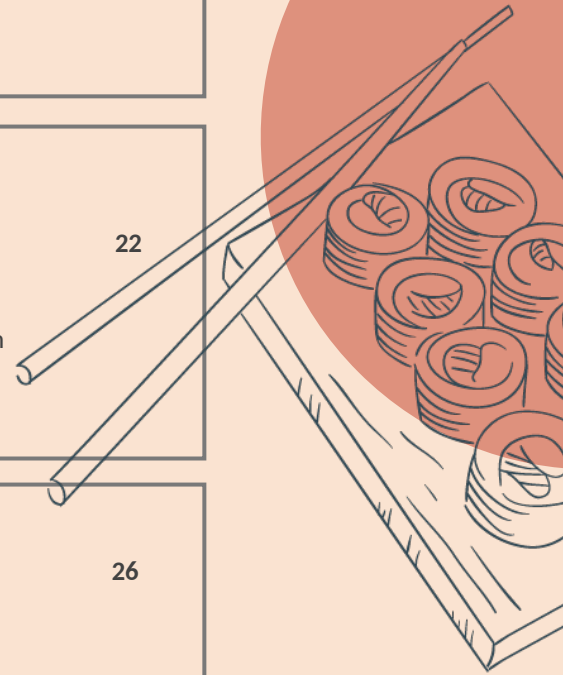

B O W L S

CURRY

Jeweils mit leicht scharfer Currysauce | Kürbis | Süßkartoffel | Erbsen | Blumenkohl | Sprossen | Zitronengras | Sesam | Kräuter | Jasmin-Reis

CURRY BOWL VEGAN	10
CURRY BOWL TOFU VEGAN	12
CURRY BOWL CHICKEN	12
CURRY BOWL CRISPY DUCK	13
CURRY BOWL FRIED SALMON	13

SATEE

Jeweils mit Erdnussauce | Kürbis | eingelegte Karottenstifte | Zuckerschoten | Sprossen | Kräuter | Jasmin-Reis

SATEE BOWL VEGAN	10
SATEE BOWL TOFU VEGAN	12
SATEE BOWL CHICKEN	12
SATEE BOWL CRISPY DUCK	13
SATEE BOWL FRIED SALMON	13

POKE

Jeweils mit Avocado | Mango | Edamame | Gurke | Daikon | Kresse | Seetangsalat | Sesam | Unagi- Sauce | Chili- Mayo | Wasabi- Mango- Mayo | Sushi- Reis

SUSHI BOWL TOFU VEGETARISCH	12
SUSHI BOWL CHICKEN	12
SUSHI BOWL SALMON	13
SUSHI BOWL FRIED SALMON	13
SUSHI BOWL SPICY TUNA	14

**S
U
P
P
E**

PHO

PHO BO

14

Rinderkraftbrühe | Entrecôte | Sprossen |
Frühlingslauch | Thai- Basilikum | Koriander |
Reisbandnudeln



**MANGO
STICKY
RICE**

MANGO KLEBREIS VEGAN

5

Mango | Klebreis | Kokosmilch | Erdnüsse

**GEMISCHTER
DESSERT-
TELLER**

GEMISCHTER DESSERTTELLER

7

Gebackene Banane | Maracuja | Vanilleeis |
Soja-Panna-Cotta | Ingwerkaramell | Sesam

**D
E
S
S
E
R
T**

