

CHAMPA

MENU

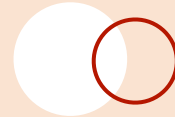
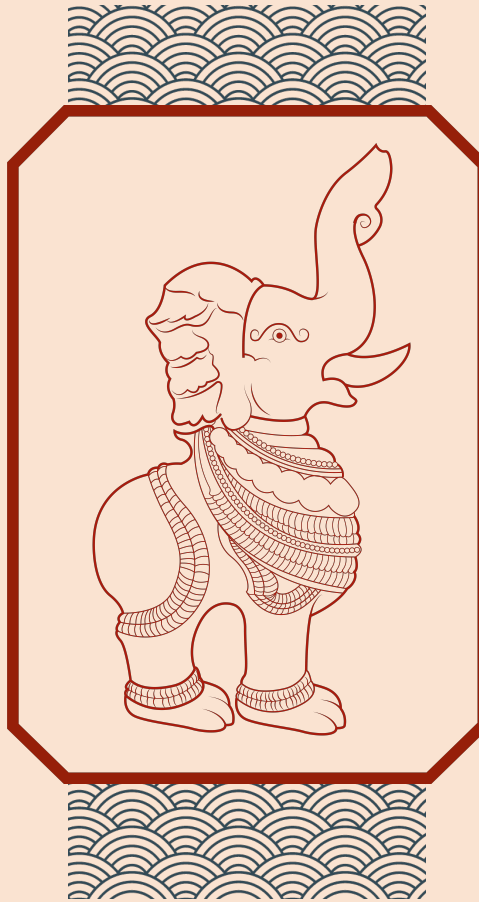

V O R S P E I S E

SUP CHAY	SAUER SCHARFE KOKOSSUPPE VEGETARISCH GEMÜSE ENOKI KOKOSMILCH KRÄUTER CASHEW SESAM	6.5
MANGO SALAT	MANGOSALAT VEGETARISCH GÜRKE KAROTTE CHINAKOHL KAROTTENSTIFTE KRÄUTER ERDNÜSSE FISCHSAUCE CHILI	6.5
FRIED CHICKEN	FRIED CHICKEN KARAAGE INGWER SOJASOBE SPICY MAYO	6.5
CHICKEN GYOZA	CHICKEN GYOZA 3 STK HÜHNCHEN KOHL KNOBLAUCH ZWIEBELN DUMPLING SAUCE	6.5
TEMPURA SHRIMP	FRITTIERTE GARNELEN 3 STK EINGELEGT KAROTTENSTIFTE SPICY MAYO	12

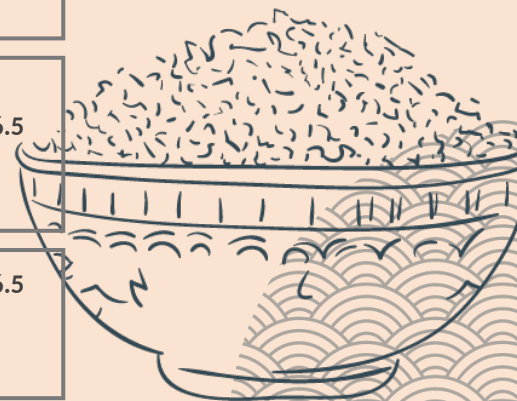

SUSHI

VORSPEISE

SPICY TUNA TATAR THUNFISCH LIMETTE DAIKON-RETTICH ROTE BEETE SESAM SCHNITTLAUCH	12.5
SALMON CARPACCIO LACHS WASABI DRESSING DAIKON-RETTICH SESAM	12.5
EDAMAME	5.5

SASHIMI (6 STÜCK)

SALMON LACHS WAKAME	12.5
TUNA THUNFISCH WAKAME	16.5
MIX SASHIMI LACHS THUNFISCH WAKAME	15

NIGIRI (2 STÜCK)

AVOCADO	5
SALMON	6.5
TUNA	7
FLAMED SALMON FLAMBIERTER LACHS SPICY MAYO TOBIKO SESAM SCHNITTLAUCH	8
FLAMED TUNA FLAMBIERTER THUNFISCH SPICY MAYO TOBIKO SESAM SCHNITTLAUCH	8.5

MAKI (6 STÜCK)

AVOCADO	5
KÜRBIS	5
SALMON	6
TUNA	6.5
CALIFORNIA KRABBFLEISCH AVOCADO MAYO	7
SPICY TUNA THUNFISCH GURKEN SCHNITTLAUCH CHILISAUCE	7

SUSHI

CRUNCHY ROLL (8 STÜCK)

VEGGIE SPARGEL GURKE PAPRIKA	7
SALMON LACHS AVOCADO	8.5
TUNA THUNFISCH AVOCADO GURKE	9

INSIDE-OUT (8 STÜCK)

GREEN VEGGIE SPARGEL GURKE KÜRBIS SESAM	7
AVOCADO ROLL AVOCADO RUCCOLA FRISCHKÄSE SESAM	7
CALIFORNIA KRABBFLEISCH AVOCADO GURKE MAYO TOBIKO	8.5
ALASKA LACHS AVOCADO GURKE FRISCHKÄSE TOKBIO	8.5
SPICY TUNA THUNFISCH CHILI GURKE SCHNITTLAUCH	9
EBI TEMPURA TEMPURA GARNELEN AVOCADO GURKE FRISCHKÄSE SESAM	9,5

SPECIAL INSIDE-OUT (8 STÜCK)

AVOCADO ROLL CRISPY SPARGEL & PAPRIKA AVOCADO	9
CHAMPA ROLL LACHS GURKE RUCOLA AVOCADO FRISCHKÄSE TOBKIO	11.5
RAINBOW ROLL KRABBFLEISCH LACHS THUNFISCH AVOCADO GURKE TOBIKO MAYO	12.5
HOT SALMON ROLL AVOCADO GURKE FRISCHKÄSE FLAMBIERTER LACHS	12.5
OUTLET ROLL TEMPURA GARNELEN LACHS AVOCADO TOBIKO	12.5

S
U
S
H
I

M
E
N
Ü

VEGAN

VEGAN

18

6 MAKI AVOCADO

6 AVOCADO ROLL

AVOCADO | RUCCOLA | FRISCHKÄSE | SESAM

6 CRUNCHY ROLL

SPARGEL | GURKE | PAPRIKA

MIXED

MIXED

23

6 MAKI AVOCADO

8 EBI TEMPURA

TEMPURA GARNELEN | AVOCADO | GURKE | FRISCHKÄSE | SESAM

8 CHAMPA ROLL

LACHS | GURKE | RUCOLA | AVOCADO | FRISCHKÄSE

**INSIDE
OUT**

INSIDE OUT

30

1 NIGIRI LACHS

8 ALASKA

LACHS | AVOCADO | GURKE | FRISCHKÄSE | TOKBIO

8 SPICY TUNA

THUNFISCH | CHILI | GURKE | SCHNITTLAUCH

OUTLET ROLL

TEMPURA GARNELEN | LACHS | AVOCADO | TOBIKO

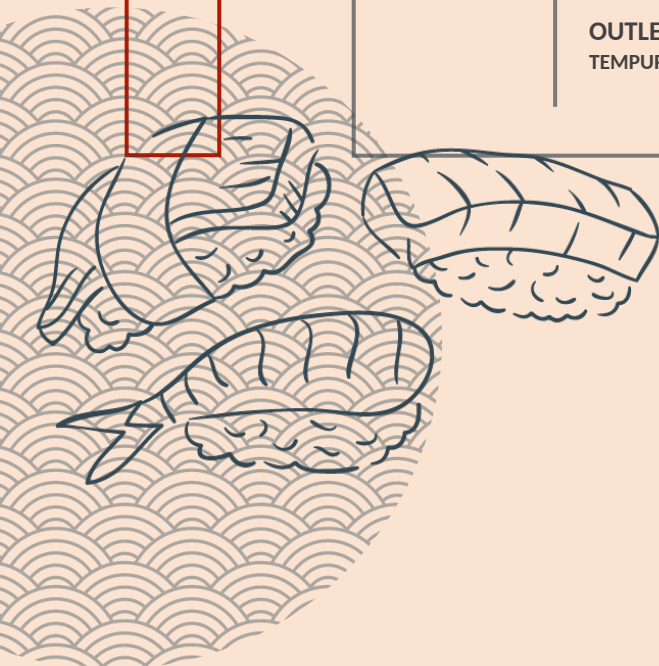
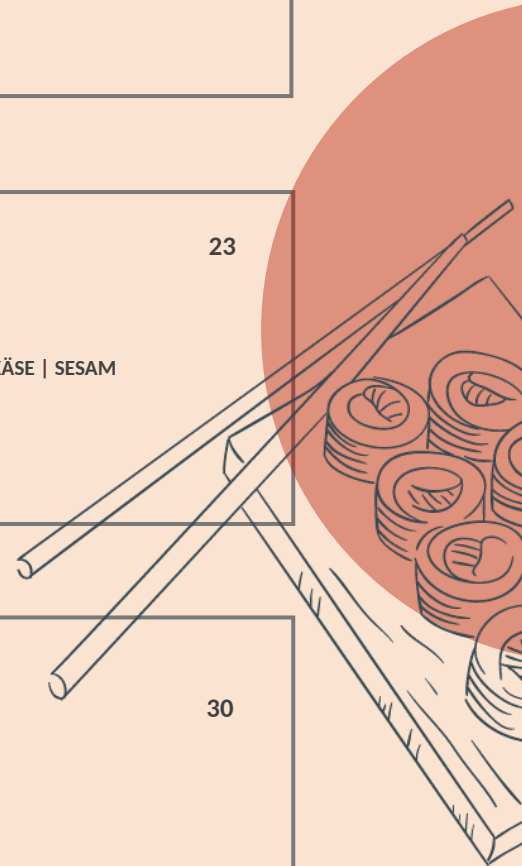

B O W L S

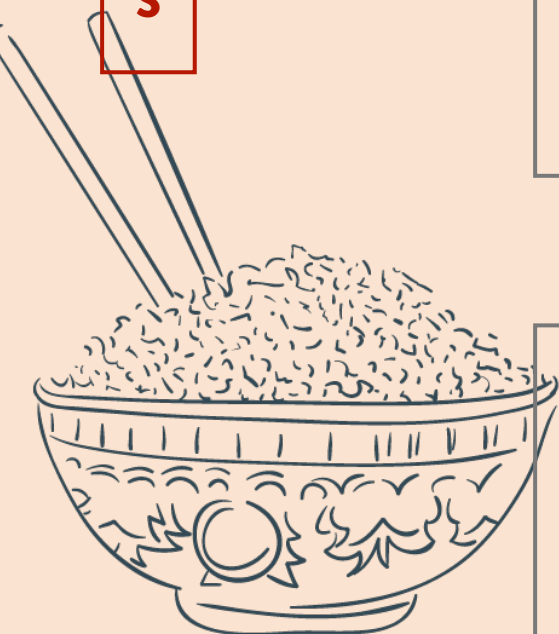

CURRY

Jeweils mit leicht scharfer Currysauce | Kürbis | Süßkartoffel | Erbsen | Blumenkohl | Sprossen | Zitronengras | Sesam | Kräuter | Jasmin-Reis

CURRY BOWL VEGAN	10.5
CURRY BOWL TOFU VEGAN	12.5
CURRY BOWL CHICKEN	12.5
CURRY BOWL CRISPY DUCK	13.5
CURRY BOWL FRIED SALMON	13.5

SATEE

Jeweils mit Erdnussauce | Kürbis | eingelegte Karottenstifte | Zuckerschoten | Sprossen | Kräuter | Jasmin-Reis

SATEE BOWL VEGAN	10.5
SATEE BOWL TOFU VEGAN	12.5
SATEE BOWL CHICKEN	12.5
SATEE BOWL CRISPY DUCK	13.5
SATEE BOWL FRIED SALMON	13.5

POKE

Jeweils mit Avocado | Mango | Edamame | Gurke | Daikon | Kresse | Seetangsalat | Sesam | Sojasauce | Chili- Mayo | Wasabi- Mango- Mayo | Sushi- Reis

SUSHI BOWL TOFU VEGETARISCH	12.5
SUSHI BOWL CHICKEN	12.5
SUSHI BOWL SALMON	13.5
SUSHI BOWL FRIED SALMON	13.5
SUSHI BOWL SPICY TUNA	14.5

S
U
P
P
E

BUN

Lauwarme Reismnudeln | Gurken | eingelegte Karottenstifte | Sprossen | Kräuter | Erdnüsse | Limetten-Fischsauce

BUN BOWL TOFU 12.5

BUN BOWL CHAR-SIU CHICKEN 12.5

BUN BOWL CRISPY DUCK 13.5

BUN BOWL FRIED SALMON 13.5

PHO

PHO BO

Rinderkraftbrühe | Entrecôte | Sprossen | Frühlingslauch | Thai- Basilikum | Koriander | Reisbandnudeln

15

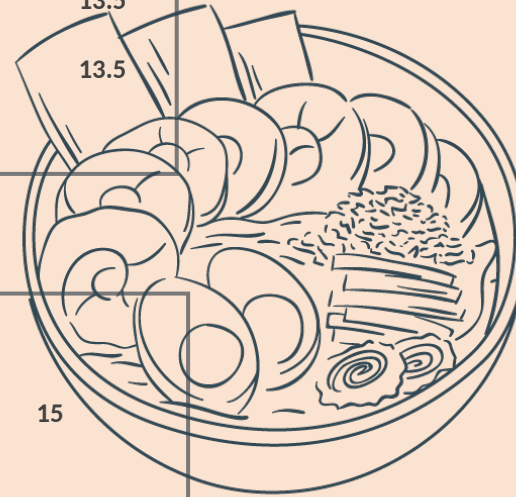

MANGO
STICKY
RICE

MANGO KLEBREIS VEGAN

Mango | Klebreis | Kokosmilch | Erdnüsse

5.5

GEMISCHTER
DESSERT-
TELLER

GEMISCHTER DESSERTTELLER

Gebackene Banane | Maracuja | Vanilleeis | Soja-Panna-Cotta | Ingwerkaramell | Sesam

7.5

D
E
S
S
E
R
T